

THE EFFECT OF MASS LIMIT CHANGES ON THIN-SURFACE PAVEMENT PERFORMANCE

John de Pont, TERNZ, PO Box 97-846, S.A.M.C., Manukau City, New Zealand.

Bruce Steven, Civil Engineering Dept, University of Canterbury, Private Bag 4800, Christchurch, New Zealand..

David Alabaster, Transit New Zealand, PO Box 1479, Christchurch, New Zealand.

ABSTRACT

Pavement design and management including road user charging in New Zealand is largely based on the well known fourth power relationship between axle loads and pavement wear. However, the vast majority of the New Zealand highway network consists of thin surface unbound pavements, which are quite different from the pavements used in the AASHO road test where the fourth power law originated. Recent proposals to improve the efficiency of the road transport system have included options to raise the axle load limits as well as the GVM and GCM. Although the fourth power law predicts an effect, the true impact of these higher axle loads on the performance of the pavements is unknown.

To determine the impact on pavement wear, an accelerated pavement test was undertaken at the Canterbury Accelerated Pavement Testing Indoor Facility (CAPTIF) to compare the wear from a 10 tonne axle with that from an 8.2 tonne axle. The two loading units at CAPTIF were configured to be the same in all respects except load. They trafficked parallel paths on four different thin-surface pavements for approximately 1 million load cycles. The pavement was extensively monitored throughout the test.

From the data collected a new empirical model of the relationship between load and vertical surface deformation has been developed. This predicts a quite different relationship between load and wear to the fourth power law and has major implications for pavement management, particularly if the mass increase is implemented, and for the road user charging regime.

INTRODUCTION

Background

As in many countries, the New Zealand road transport freight industry is constantly searching for efficiency improvements. One of the obvious ways to achieve these is through increases in the allowable masses for heavy vehicles. These could result in economic benefits to the whole country provided the impact of the changes in mass limits are accurately known and considered in assigning the new limits and in determining appropriate road user charges. Of concern to the road-controlling authorities is the effect on increasing mass limits on the life of the pavements and how much more pavement rehabilitation and maintenance will be required.

In response to the industry's requests for larger and heavier vehicles Transit New Zealand (2001) has recently undertaken a study to assess the economic and safety impacts of increasing mass limits. This study investigated two scenarios:-

- Scenario A, where heavier vehicles subject to the same dimensional limits as are currently in place would be permitted to operate across the entire network and
- Scenario B, where longer and heavier vehicles would be permitted to operate only a selected set of key routes.

Within these two scenarios several gross combination mass limits were considered and associated with these increased axle mass limits. Transit's evaluation of these proposed changes in mass limits included research into

the safety, geometric, economic, pavement and bridge impacts. In determining the pavement wear impact of these mass limits changes, existing theories for the relationship between vehicle loads and pavement wear were utilised. The most widely used existing theory for determining the effect of mass limit increases on pavement life is the fourth power rule. This is used to determine the pavement loading as a number of Equivalent Standard Axles (ESAs). The formula for converting an actual axle load to ESA is:

$$ESA = \left[\frac{\text{Actual axle load}}{\text{Reference axle load}} \right]^4$$

This fourth power relationship between axle loads and pavement life has never been validated on New Zealand's thin surfaced unbound granular pavements. Power values between 1 and 8 have been suggested by different researchers throughout the world for different pavement structures and failure mechanisms (Cebon, 1999, Kinder and Lay, 1988, Pidwerbesky, 1996). Even the Austroads Pavement Design Guide, which is the basis of New Zealand design practice, uses a power of 4 for unbound basecourse performance and a power of 7.14 for subgrade performance.

The use of a fourth power relationship predicts that increasing the allowable loading for a single axle from 8.2 tonne (current limit) to 8.8 tonnes (proposed new maximum) will result in a 33% increase in pavement wear. On this basis a road controlling authority might expect a 33% increase in the length of pavement rehabilitation required per year. The actual situation is not as extreme as this because in the first place not all vehicles will change to the higher limits and secondly the higher axle load limits will result in higher payloads and consequently fewer trips for the same freight volume. Nevertheless, this change will represent a significant increase in annual expenditure on roads for a road controlling authority and requires budgeting for. The uncertainty in the validity of the fourth power rule poses difficulties when requesting increases in funding for the next financial year. Justifying an increase in the road user charges based on a fourth power rule that has not been validated in New Zealand is expected to be increasingly difficult, particularly as research results from accelerated pavement tests are suggesting different relationships.

This study investigates, via accelerated pavement testing on typical New Zealand pavement designs, the relative effect on pavement performance of an increase in axle load from 8.2 tonnes (the present load limit) to 10 tonnes. This increase is somewhat higher than the originally proposed change. There are two reasons for using this higher axle load. The first is that in response to the heavy vehicle limits study, the bus and coach industry has suggested that this level of increase should be considered. The second is that the larger mass difference between the two wheel paths was more likely to ensure that the difference in wear is sufficiently large to be able to draw clear conclusions. By interpolating the results of this research it would be possible to assess the effect on pavement life of loading increases directly (without necessarily using any power law). A more detailed report on this test (de Pont et al, 2001) has been published by Transfund New Zealand.

A key issue for this study is what constitutes pavement wear. The OECD DIVINE project (OECD, 1998) differentiates between functional and structural condition for pavements. Functional condition reflects the ability of the pavement to provide service to the road user and covers factors such as roughness, rutting and skid resistance. Structural condition relates to the ability of the pavement to support the loads applied to it and relates to cracking and other forms of distress. In some instances a loss of functional condition may also indicate a loss of structural condition. In New Zealand pavement maintenance and rehabilitation is driven primarily by measures of functional condition and thus, in this study, wear is taken to mean a reduction in functional condition. The primary measure of functional condition considered in this paper is permanent vertical surface deformation (VSD). VSD is the change in elevation of the pavement surface from a reference elevation measured at the start of testing.

The Canterbury Accelerated Pavement Testing Indoor Facility (CAPTIF)

CAPTIF is located in Christchurch. It consists of a 58 m long (on the centreline) circular track contained within a 1.5m deep x 4m wide concrete tank so that the moisture content of the pavement materials can be controlled and the boundary conditions are known. A centre platform carries the machinery and electronics needed to drive the system. Mounted on this platform is a sliding frame that can move horizontally by 1 m. This radial movement

enables the wheel paths to be varied laterally and can be used to have the two “vehicles” operating in independent wheel paths. An elevation view is shown in Figure 1.

At the ends of this frame, two radial arms connect to the Simulated Loading and Vehicle Emulator (SLAVE) units shown in Figure 2. These arms are hinged in the vertical plane so that the SLAVEs can be removed from the track during pavement construction, profile measurement etc. and in the horizontal plane to allow vehicle bounce. CAPTIF is unique among accelerated pavement test facilities in that it was specifically designed to generate realistic dynamic wheel forces. All other accelerated pavement testing facility designs we are aware of attempt to minimise dynamic loading. The SLAVE units at CAPTIF are designed to have sprung and unsprung mass values of similar magnitude to those on actual vehicles and use, as far as possible, standard heavy vehicle suspension components. The net result of this is that the SLAVEs apply dynamic wheel loads to the test pavement that are similar in character and magnitude to those applied by real vehicles. This was a significant factor in its selection for this project. A summary of the characteristics of the SLAVE units is given in Table 1. The configuration of each vehicle, with respect to suspensions, wheel loads, tyre types and tyre numbers, can be identical or different, for simultaneous testing of different load characteristics.

A more detailed description of the CAPTIF and its systems is given by (Pidwerbesky, 1995).

OBJECTIVE

The principal objective of the study was to determine the effect on pavement life and pavement performance of increasing the maximum allowable axle load for different pavement strengths (or aggregate depth) using data from an accelerated pavement test.

Based on this effect the aim was then to predict the increase in road expenditure resulting from an increase in the allowable axle loads and thus justify to the transport industry the increase in Road User Charges (RUCs) that would be required to offset this expenditure.

RUCs for heavy vehicles in New Zealand are based on mass and distance. The rates are based on the fourth power law so an increase in axle load will lead to a substantial increase in RUCs for vehicles with these more heavily loaded axles. The purpose of the second objective is to assess whether this level of increase is appropriate.

METHOD

Pavement design

The objective of the pavement design was to produce the relatively low levels of rutting observed in typical New Zealand Pavement while maintaining a balance between the life of the heavily loaded (10 tonne) outer wheel path and the lightly loaded (8.2 tonne) inner wheel path.

The track was divided into four sections with the same depth of a different basecourse material in each. The original experimental design called for only one basecourse material and different thicknesses but this was changed to accommodate the requirements of another project that needed to use data from the same test. The four pavement sections were not considered separately in the design as the material data available at the design stage was not sufficient to consider separate designs for each material. It was considered preferable to use pavements of the same depth in order to limit the number of variables in the project.

The pavement was designed in an iterative manner using the AUSTRROADS Pavement design guide. The iterative designs assumed a 700 kPa tyre pressure with a 95.6 mm tyre radius on the inner wheel path and a 850 kPa tyre with a 97mm tyre radius on the outer wheel path. The basecourse layer was, from previous experience, modelled with a modulus of 400 MPa using AUSTRROADS sub-layering and, as convention dictates, the thin asphaltic layer was not considered in the analysis. The subgrade was modelled with a 10th percentile design in-situ CBR of 10, based on test results at the top of the subgrade layer and used the standard 10 times CBR relationship to obtain the modulus.

The iterative analysis suggested the inner (8.2 tonne) wheel path would require a basecourse 250 mm deep to withstand the design 1,000,000 wheel passes and a depth of 290 mm for the outer wheel path assuming the AUSTRROADS subgrade strain criterion. Using the 4th Power law to convert the 10 tonne wheel to an equivalent number of standard axles rather than modelling directly suggested that the outer wheel path would have needed to be 270 mm deep.

The final design used a 275mm basecourse layer. Theoretically this was expected to fail at 2.9 million passes of the 8.2 tonnes axle and at 600,000 passes of the 10 tonne axle assuming the AUSTRROADS subgrade strain criterion and directly modelling the tyre loads. Using the 4th power law suggested that the 10 tonne axle would cause failure at 1.2 million passes.

Pavement construction

The pavement was constructed in three primary segments: Segment A extended from station 00 to station 15; Segment B from 15 to 29; and Segment C from 29 to 43. An additional segment, Segment D, extended through the track access area from 43 to 00. There was a 4m transition zone allowed between segments. Within each segment on the track centreline there were 3 primary sites for intensive monitoring and 14 secondary sites for less intensive monitoring. A plan showing the layout of the different sections is shown in Figure 3.

Pavement construction at CAPTIF as far as possible utilises the same techniques as used for normal pavement construction in New Zealand. The main variations are that there is some scaling of the equipment because of the size of the track and some adaptations because of the curvature of the track. For example, a plate compactor is used for final compaction rather than a roller. The other big difference is that as each layer is placed it is intensively monitored to ensure that the pavement has a high degree of uniformity, particularly transversely. These measurements include density, moisture content, elevation, transverse profile, Loadman deflections, CBR, and penetrometer readings. In addition instrumentation to measure strains and stresses was placed within the layers during construction.

Zero measurements

Basic measurements of the surface profile and structural capacity of the pavement as constructed were undertaken. The SLAVE units were then loaded to 40kN each and 5,000 preliminary conditioning load cycles (10,000 ESA) were applied evenly across the full trafficable width of the pavement. Following these conditioning laps, a set of zero measurements to characterise the system at the start of the test were undertaken.

These measurements included:

- Loadman falling weight deflectometer measurements to monitor the structural capacity of the pavement layers during construction and CAPTIF deflectometer measurements on completion of construction.
- Transverse profiles at each of the 58 stations using the CAPTIF transverse profilometer. These are referenced back to the tank wall and give elevation readings at 25mm spacing across the track.
- Longitudinal profiles measured along five centrelines using the laser profilometer. The five centrelines consisted of one in the centre of each wheel path, one midway between the two wheel paths, one inside the inner wheel path and one outside the outer wheel path.
- The effect on pavement response to varying the transverse position of the SLAVE units was measured with ten sets of readings with the offset changing by 0.1m each time.
- The effect of speed variations was recorded by taking measurements at 20km/h and 45 km/h. For these measurements the vehicles were loaded to the test condition with 40kN on vehicle A and 50kN on vehicle B.
- The effect of variations in load was measured by setting the load on vehicle A to 21kN, 31kN, 40kN, 44kN and 50kN. The load on vehicle B was 50kN throughout these tests.
- Characterising the suspension response using the 80mm drop test at crawl speed as specified by the EC (Council of the European Communities, 1992) in their regulations for rating a suspension as "equivalent-to-

air". For these measurements the vehicles were in the test load configuration with vehicle A at 40kN and vehicle B at 50kN.

The vehicles were weighed by standard New Zealand Police portable weigh scales at their operating configuration. The static weight for vehicle A was 4080 kg (40.02 kN) and the static weight for vehicle B was 5060 kg (49.64 kN).

Testing

For this project the SLAVE units were run in concentric offset wheel paths. Previous projects where the SLAVE units were run in offset wheel paths had used wide single tyres. However this project specified the use of standard dual tyre assemblies. As the dual tyre assembly is considerably wider than a wide single tyre this requirement significantly reduced the separation between the two vehicles, even with a narrow wander pattern. To overcome this limitation, a 300 mm long extension section was fitted to arm B. This meant that the radial distance between the centrelines of the vehicles was 1100 mm and the clear separation between the vehicles was 450 mm with the vehicles operating on a ± 50 mm normally distributed wander pattern.

The vehicles were run continuously at a mean speed of 45km/h with breaks for testing intervals at 20,000, 30,000, 50,000, 100,000, 150,000, 200,000, 250,000, 300,000, 400,000, ... 1,000,000 cycles. Starting at 20,000 cycles, every third test comprised a full set of tests that included: 58 transverse profiles; 5 longitudinal profiles; pavement strain and pressure readings at 45km/h and 15km/h; and dynamic wheel loads at 45km/h. At the other test intervals a reduced data set was taken. The reduced data set included: 58 transverse profiles; longitudinal profiles in the wheel paths only; and strains and pressures at 45km/h only. The Falling Weight Deflectometer was used to measure all stations in both wheel paths at 25,000, 200,000, 600,000, and 1,000,000 cycles.

After 200,000 laps the asphaltic concrete surfacing in Segment C began to show signs of shear failures in the outer (50kN) wheel path only. When the seal was removed it was noted that the top of the basecourse looked glazed and dirty with no significant bonding of the asphalt mix to the basecourse material. The damaged sections of seal were replaced but the problem recurred at 700,000 and 1,000,000 cycles in different places in the outer wheel path in section C.

Loading was halted after 1,000,000 cycles as specified in the research the brief. Although the pavement had not reached any of the predefined failure criteria, the rate of pavement deterioration (rutting) in both wheel paths had reached a stable state and failure would not occur for many more load cycles.

Post-mortem

The post-mortem analysis consisted of recording the condition of the pavement and excavating trenches across the width of the pavement to determine any changes in the properties of the different materials and to attempt to determine the amount of rutting in each layer. Three trenches were excavated in each section, at locations corresponding to the minimum, average and maximum locations of pavement rutting.

RESULTS AND ANALYSIS

Pavement Variability

In constructing a pavement at CAPTIF for a comparative study such as this the aim is to minimise the transverse variability in the pavement structure so that the two SLAVE units are, as much as possible, trafficking identical pavements. Longitudinal variations in the pavement structure are less of a concern but it is difficult to construct a pavement that is very uniform transversely and irregular longitudinally. To test a parameter such as layer thickness for uniformity between the two wheel paths we construct a new variable, which is the difference between the parameter's value on the inner wheel path and its value at a position on the same radial line in the outer wheel path. For a uniform pavement this new variable will have a mean equal to zero and a small standard deviation.

Table 2 and Table 3 show the statistics of this difference variable for the asphalt and basecourse layer thicknesses respectively. At the 95% confidence level, if the range of the average difference $\pm 2 \times$ standard error includes zero, then we cannot reject the null hypothesis that there is no difference between the inner and outer wheel paths. From

Table 2 we can see that for the asphalt layer, only segment C shows no difference between the inner and outer wheel paths. For pavement segments A and B the inner wheel path asphalt layer is approximately 5 mm thicker than the outer wheel path while, for segment D, the outer wheel path is approximately 2mm thicker. The average asphalt layer thickness for the whole pavement is about 27mm. Although the 5mm difference is a significant proportion of the overall layer thickness, thin surface pavement design assumes that the asphalt layer does not contribute to the structural capacity of the pavement and so this should not impact significantly on the performance of the two wheel paths.

From Table 3, which shows the analysis of the basecourse layer we can see that Segments B, C and D have an average, which is not significantly different from zero at the 95% confidence level. The average for Segment A is greater than zero but only just outside the 2 standard error confidence interval and as the average thickness of the basecourse layer is 276 mm the difference is less than 2%. The basecourse layer is the main structural element in a thin-surface pavement and to all intents and purposes the inner and outer wheel paths have the same thickness basecourse layer.

During construction Loadman falling weight deflectometer measurements of the modulus were taken at five transverse positions at twelve stations (three in each pavement segment) on the top of the subgrade layer. As the same subgrade was used for all four segments we consider the difference function on this layer for the whole track. This had a negative mean (average value -7 MPa with a standard error of 3.4MPa). The average value for both wheel paths was 68 MPa, so the inner wheel path average was 10% below the outer wheel path. For the basecourse layers readings were taken at nine stations (three in each of segments A, B and C. At the 95% confidence level there was no significant difference in the readings between the two wheel paths either by segment or for the pavement as a whole. Experience with the Loadman at CAPTIF has shown the repeatability of the results to be approximately 10 MPa. Thus, based on the Loadman measurements the inner and outer wheel paths appear to be effectively identical.

Vertical Surface Deformations and Rutting

At each measurement interval the transverse profile of the pavement was measured at each station. From these measurements the permanent vertical surface deformation (VSD) and the rut depth can be calculated. VSD has proved in past CAPTIF tests (de Pont et al., 1999) to be a fundamental measure of pavement wear that provides useful insights into the pavement performance and behaviour. Both rutting and surface roughness are related to VSD and so VSD reflects both these forms of pavement wear. Rutting is a direct result of VSD while roughness is the result of the variation in VSD. As VSD has been shown to be correlated to both dynamic wheel forces and the variability in pavement structure (de Pont et al., 1999), increasing VSD leads to increased roughness. With the transverse profiler at CAPTIF it is possible to measure VSD to a good degree of accuracy and reliability because the measurements are all referenced back to the edges of the concrete tank which are very stable.

Measurements of rutting and roughness do not have the same level of reliability (de Pont, 1997). Rutting is determined by calculating or measuring the depth of the rut from a straight edge laid across the wheel path. Thus the rut depth depends not only on the VSD in the centre of the wheel path but also that of the highest tangential points inside and outside the wheel path. Roughness is usually given in International Roughness Index (IRI) values, which are calculated from the longitudinal profile using the response of simulated quarter car. The dynamic characteristics of the quarter car are such that it responds to surface profile characteristics with wavelengths from 1m to 30m (Sayers et al., 1986). To accurately sample the longer wavelength components in this range it is normally recommended that the section length for IRI calculation is greater than 100m. As the track at CAPTIF is only 58m long it does not meet this requirement.

Figure 4 and Figure 5 show the progression of VSD for each of the wheel paths in each pavement segment. Note that, as outlined in the test description, earlier parts of the pavement surface in the outer wheel path in segment C were repaired at 200,000 cycles and at 700,000 cycles. The VSD values for these repaired sections were therefore meaningless and so the average VSD for the outer wheel path of segment C is calculated from only those stations that had not been repaired. This left only four stations out of fourteen so it is expected that the variability will be greater for this dataset.

For all four pavement segments the VSD is greater on the outer wheel path, which was trafficked with the higher load than on the inner. The conventional approach to comparing the wear generated by two different axle loads is the power law method. This states that the amount of pavement wear caused by one pass of an axle is proportional to some power of its axle load. The most widely used value for this power is four. Thus if a given level of wear is achieved by N_{inner} load cycles of a load P_{inner} or by N_{outer} load cycles of a load P_{outer} these are related as follows:

$$\frac{N_{inner}}{N_{outer}} = \left[\frac{P_{outer}}{P_{inner}} \right]^n$$

where n is the exponent of the power law

For every measured value of VSD and load cycles on the inner wheel path, the number of load cycles on the outer wheel path to generate the same VSD can be calculated by interpolation. Alternatively the number of load cycles on the inner wheel path needed to generate the measured VSDs in the outer wheel path can be calculated. In either case, as P_{inner} and P_{outer} are known, the value of the exponent, n , required to get the power law relationship to hold can be calculated for each VSD value. Whether the inner or outer wheel path VSD measurements are used as the reference makes relatively little difference to the results. For segment A, the average exponent value was 8.9 using the inner wheel path VSDs as the reference and 9.3 using the outer wheel path VSDs. For segment B, the corresponding values were 6.1 and 6.3, for segment C, 2.8 and 2.9 and for segment D, 3.8 and 3.9. Averaging across both sets of data gives exponents of 9, 6.2, 2.8 and 3.8.

Using these values in a model gives a reasonable fit to the measured data. If we use 8.2 tonnes as a standard axle load every load cycle on the inner wheel path corresponds to 1 "equivalent standard axle" or ESA. On the outer wheel path each load cycle would correspond to $(10.2/8.2)^n$ ESA where n is the exponent calculated above. Thus for segment A, where the exponent is 9, 1,000,000 load cycles corresponds to 5,966,000 ESA. Figure 6 shows the power law fits for each of the pavement segments. As can be seen this form of model provides a reasonable although far from perfect fit to the data. However, there are two major problems with this model. The first is that it does not explain why the rate of increase in VSD changes so much as the loading progresses and the second is that there is such a wide variation in the value of the exponent between the different pavement segments. These four segments are all variations of a basic thin surface pavement structure and yet the best-fit exponents for a power law model vary between less than 3 and 9.

Looking back at Figure 4 and Figure 5, we can see that VSD increases rapidly during the initial loading cycles and then slows to an approximately linear rate of increase. This suggests that the VSD consists of two components, an initial post construction compaction and then a wear related component. If we fit a straight line to the linear part of the VSD versus load cycles curve, then the intercept of this line with the vertical axis gives the post construction compaction component and the slope of the line gives the wear related component. We can then use the power law approach to compare both the intercept and the slope of these lines between the inner and outer wheel path for each segment.

Table 4 and Table 5 show the results of a least squares regression straight line fit to the linear portions of the VSD vs load cycles curves for each of the four segments in both wheel paths. As can be seen from the r^2 statistics these are very good fits.

A power law fit can be applied to the compaction and wear components independently. This power law approach implies relationships of the form:

$$\frac{\text{Intercept}_{outer}}{\text{Intercept}_{inner}} = \frac{\text{Compaction}_{outer}}{\text{Compaction}_{inner}} = \left(\frac{\text{Axle load}_{outer}}{\text{Axle load}_{inner}} \right)^n \text{ where } n \text{ is the exponent of the power law}$$

$$\frac{\text{Slope}_{outer}}{\text{Slope}_{inner}} = \frac{\text{Wear}_{outer}}{\text{Wear}_{inner}} = \left(\frac{\text{Axle load}_{outer}}{\text{Axle load}_{inner}} \right)^n \text{ where } n \text{ is the exponent of the power law}$$

Using logarithms the values of n can readily be calculated for compaction and wear for each of the pavement segments. The results for the exponent values are shown in Table 6. It is interesting to note how similar the exponents are for the two components of VSD. The exponents for the different segments, while still not identical, are much more alike than they were in the simple power law model, particularly if we discount segment C. Recall

that a number of stations in the outer wheel path of segment C were repaired during the test and that the data from these stations were removed from the analysis leaving only four valid stations.

This model implies that the compaction is dependent only on the applied wheel load and not on the number of applications of this load (although a number of applications of the load are required to effect the compaction). The wear component is related to both the load and the number of load cycles. A logical extension to this model is that if after some large number of load cycles, the wheel load is increased the additional compaction associated with the higher wheel load would then take place as well as the higher rate of wear associated with a higher wheel load. The conventional power law approach does not predict an additional compaction with an increase in wheel load, only a higher wear rate.

Although this hypothesis was not tested explicitly because the test was completed before this analysis was done, there was a series of higher load cycles applied to the inner wheel path after the completion of this test as part of another project. VSD measurements were taken as part of that project and the results are shown in Figure 7. The project being reported here was finished at 1,000,000 load cycles. The subsequent project involved looking at the strain response of the pavement under various loading conditions, which included loads 40kN, 50kN and 60kN with varying tyre pressures and on both wide single and dual tyres. Thus it is difficult to make a direct assessment of the expected wear impact. However, the change in VSD after 1,000,000 load cycles does appear to reflect an additional compaction rather than just a change in wear rate.

Previous work at CAPTIF on the impact of dynamic loading on pavement wear (de Pont et al., 1999) also found a power law relationship for wear rate that had a relatively low exponent (between 1 and 2). This fits in well with exponent values found for this compaction and wear model and not with the higher powers normally associated with a power law model.

Note that the terms "compaction" and "wear" to describe the two components of VSD are not based on any knowledge of the underlying material behaviour. Previous measurements by (Patrick et al., 1998) measuring the density of in-service pavements found no significant increase in basecourse density during this post-construction compaction phase. Further investigation is needed to determine the mechanism generating the behaviour.

If this model is correct there are significant implications for road controlling authorities particularly if a change in axle load limit occurs. The wear rate will increase according to a power law with an exponent between 1.8 and 3. This means that if the axle load limit is raised by 7.3% as suggested the wear rate per axle for those axles at the higher loads will increase by between 13.5% and 23.5% depending on which exponent value is used. As road user charges are based on a fourth power law the increase in wear component of road user charges will be 32.5% for the higher loaded axles and thus will more than offset the additional wear. However, the compaction component also has an exponent of between 1 and 3.4. Increased axle loads will therefore also cause an additional one-off compaction of the pavement across the whole network. For a 7.3% axle load increase this will be between 7.3% and 27% of the compaction that occurred initially on the pavement after construction. For the four pavement segments tested here the magnitude of the initial compaction was equivalent to the wear induced by between 700,000 and 980,000 load cycles. Thus an increase in axle load limit of 7.3% would lead to an increase in VSD due to compaction which is equal in magnitude to the wear-related VSD associated with between 50,000 and 265,000 load cycles. For a typical New Zealand State Highway, the average heavy vehicle traffic is about 100 vehicle/day and it is assumed that the average heavy vehicle applies about 1 ESA. This implies about 36,500 standard axle loads per year. Thus increasing the axle load limit by 7.3% will result in an additional compaction that is equivalent to between 1.4 and 7.3 years of normal loading. This additional VSD would occur in a relatively short period, probably less than a year, of the change.

CONCLUSIONS

The aim of this study was to compare the pavement wear generated by a 10 tonne axle load with that of a standard 8.2 tonne axle with a view to predicting the cost implications of a change in the legal axle load limit in New Zealand. A pavement was tested at CAPTIF, which comprised four distinct segments, each of which was similar in design but utilised a different basecourse material. One of the SLAVE units at CAPTIF was configured to generate a 40kN wheel load (equivalent to an 8.2 tonne axle) and the other was configured for a 50kN wheel load (equivalent to just over 10 tonne axle load). The two SLAVEs were then used to apply 1,000,000 load cycles to

parallel wheel paths on the pavement. During the testing measurements were taken to record the pavement wear, the pavement condition, the pavement response to the vehicle loading and the vehicle response to the pavement.

From these measurements a number of important findings can be deduced:

- VSD, which is a fundamental measure of pavement wear that results in both rutting and increased surface roughness, again proved to be useful for monitoring pavement wear at CAPTIF.
- Although a conventional power law relationship could be fitted to describe the differences in VSD between the two levels of loading for each of the four pavement segments, there was a large variation (between 2.8 and 9) in the exponent value required to give the best fit. As the pavement design of the four segments was substantially similar in character it does not seem reasonable that the exponents for a power law model should vary so much. It also makes it impossible to predict the appropriate exponent value in advance. Thus the power law approach does not appear to be an accurate or useful way of modelling the VSD wear of this type of pavement.
- Reviewing the progression of VSD with load cycles shows that the pavement underwent two distinct phases of VSD. There was an initial period of rapid change, which we will call compaction, followed by a period with a constant (linear) rate of change, which we will call wear. Least squares regression can be used to fit a straight line to the linear part of the VSD versus load cycles curve. The intercept of this line with the y-axis then gives the compaction component and the slope gives the wear. For each of the four pavement segments, a power law can be used to relate the compaction and wear between the normally and more heavily loaded wheel paths. Remarkably the best-fit exponent values for compaction and wear were quite similar for each pavement segment and did not vary too much between segments.
- This compaction-wear model implies that the compaction depends only on the magnitude of the applied load and not on the number of load cycles while the wear depends on both the load and the number of load applications. A corollary of this is that if the axle load level is increased at any stage further compaction will occur to reflect this higher load. As this model was developed well after the completion of the testing programme this hypothesis was not specifically tested for, but in the project that followed this one at CAPTIF, the same pavement was used and higher loads were applied to the more lightly loaded wheel path. The VSD did show an apparent increased compaction as would be expected.
- The exponent values for the compaction-wear model were between 1 and 3.4 for compaction and 1.8 and 3 for wear. (The values for pavement segment C were a little lower than this but repairs to the pavement surface during the test meant that very few data points could be used for this segment.) The implication of this is that if the axle load limit were increased the underlying wear rate would increase as indicated by a power of between 1.8 and 3. As the road user charges paid by these vehicles are based on a power of 4 the additional road user charges would more than offset the additional wear. In fact, there is some ground for considering a review of the road user charges schedule. But it must be noted the effect of the compaction phase will also be observed in new construction and rehabilitation so this effect cannot be ignored. The existing fourth power approach is based on a chord approach, that is, the amount of damage is considered only at the initial and terminal conditions. This research has shown that there maybe some merit in looking at a secant (tangential) rate of damage, but this approach would be difficult to incorporate into a charging model. However, an increase in axle load limit would also cause an immediate (over a year or two) additional compaction. Thus it would appear that the network had suddenly deteriorated substantially. This is a one-off effect but would need to be planned for by the road controlling authorities if pavement condition is to be maintained. If the road controlling authorities are not anticipating this additional compaction effect, the sudden apparent additional deterioration of the network will cause them great concern over the future maintenance demands.

From these findings a number of questions requiring further investigation arise:

- Further validation of the compaction-wear model is required. It is recommended that, in future CAPTIF trials where a wheel path has been trafficked with a constant load, after completion of the test some relatively small number (perhaps 300,000) load cycles with a higher load are applied. If the compaction-wear model is valid it will be possible to predict and test the amount of compaction that will occur. Work in progress at CAPTIF (2001) has attempted to address this issue but additional validation will be required.
- Although the compaction-wear model provides a good fit to the observed behaviour and is a useful predictor tool, the mechanisms underlying it are not understood. Further research is required to determine how the pavement materials are behaving and what is leading to the compaction and wear components of VSD. Note that the names, "compaction" and "wear" are speculative and not based on any fundamental consideration of the underlying material behaviour.
- More detailed analysis of the cost implications of the compaction-wear model are needed. The underlying wear rate appears to be related to load by a power lower than four. However, the compaction component is also related to load by a power law.
- The VSD associated with compaction is equivalent to the wear associated with a considerable number of load cycles. If this compaction can be induced without causing rutting or roughness, the performance of the pavement would be enhanced considerably. How this could be achieved requires further investigation.
- The performance of thin surfacings under the higher axle loads needs to be investigated further. The

pavement surfacing exhibited distress and failures under the 50 kN axle load, but not the 40 kN axle load.

Overall the most significant finding of this study is the development of the compaction-wear model for VSD. This provides a much better fit to the observed behaviour than the conventional power law model and has very significant implications for pavement management practice in New Zealand and wherever thin surface unbound pavement structures are widely used. Further validation work should be undertaken as well as research to understand the material behaviour mechanisms that produce this behaviour.

REFERENCES

- Cebon, D. 1999. Handbook of vehicle-road interaction. Swets & Zeitlinger, Lisse, Netherlands.
- Council of the European Communities. 1992. Annex III of the Council Directive 92/7/EEC amending Directive 85/3/EEC on the weights, dimensions and certain technical characteristics of certain road vehicle. Council of European Communities. Brussels.
- de Pont, J. 1997. OECD DIVINE project - Element 1. Longitudinal pavement profiles. Industrial Research Limited IRL report no. 708, Industrial Research Limited, Auckland.
- de Pont, J., Steven, B. and Pidwerbesky, B. 1999. The relationship between dynamic wheel loads and road wear Transfund New Zealand Research report No. 144 88 p., Transfund New Zealand, Wellington.
- de Pont, J., Steven, B. Alabaster, D. and Fussell, A. 2001. Effect on pavement wear of an increase in mass limits for heavy vehicles. Transfund New Zealand Research report No. 207, Transfund New Zealand, Wellington.
- Kinder, D. F. and Lay, M. G. 1988. Review of the fourth power law. Australian Road Research Board ARRB Internal Report AIR 000-248, ARRB, Victoria.
- OECD 1998. Dynamic interaction between vehicles and infrastructure experiment (DIVINE). OECD Technical report IRRD 899920, OECD, Paris.
- Patrick, J. E., Alabaster, D. J. and Dongol, D. M. S. 1998. Pavement density Transfund New Zealand Research Report 100, Transfund New Zealand, Wellington.
- Pidwerbesky, B. D. 1995. Accelerated dynamic loading of flexible pavements at the Canterbury accelerated pavement testing indoor facility. Transportation Research Record 1482 pp79-86.
- Pidwerbesky, B. D. 1996. Fundamental behaviour of unbound granular pavements subjected to various loading conditions and accelerated trafficking. University of Canterbury. Research report 96-13
- Sayers, M. W., Gillespie, T. D. and Paterson, W. D. O. 1986. Guidelines for conducting and calibrating road roughness measurements World Bank technical paper 46.
- Transit New Zealand. 2001. Heavy Vehicle Limits Project, Report 7. Overview Part 1: Main Report. Transit New Zealand, Wellington.

TABLES & FIGURES

Table 1. Characteristics of SLAVE units.

Test Wheels	Dual- or single-tyres; standard or wide-base; bias or radial ply; tube or tubeless; maximum overall tyre diameter of 1.06 m
Mass of Each Vehicle	21 kN to 60 kN, in 2.75 kN increments
Suspension	Air bag; multi-leaf steel spring; single or double parabolic
Power drive to wheel	Controlled variable hydraulic power to axle; bi-directional
Transverse movement of wheels	1.0 m centre-to-centre; programmable for any distribution of wheel paths
Speed	0-50 km/h, programmable, accurate to 1 km/h
Radius of Travel	9.2 m

Table 2. Difference (inner – outer wheel path) in asphalt layer thickness.

Segment (Station Nos)	Average (mm)	Minimum (mm)	Maximum (mm)	Standard Deviation (mm)	Range (mm)	Standard Error (mm)
A (0-15)	4.92	-1.38	14.25	4.13	15.63	1.03
B (16-29)	4.89	-3.00	10.38	3.74	13.38	1.00
C (30-43)	0.16	-4.75	6.13	3.45	10.88	0.92
D (44-57)	-1.79	-2.13	-1.25	0.47	0.88	0.27

Table 3. Difference (inner – outer wheel path) in basecourse layer thickness.

Segment (Station Nos)	Average (mm)	Minimum (mm)	Maximum (mm)	Standard Deviation (mm)	Range (mm)	Standard Error (mm)
A (0-15)	5.13	-10.13	25.25	9.81	35.38	2.45
B (16-29)	-3.94	-15.75	11.25	7.59	27.00	2.03
C (30-43)	1.93	-8.00	9.88	4.76	17.88	1.27
D (44-57)	0.21	-1.25	2.25	1.82	3.50	1.05

Table 4. Linear fit parameters for VSD vs load cycles on inner wheel path.

	Intercept – Compaction (mm)	Slope – Wear rate (mm/1000 load cycles)	Goodness of fit – r^2
Segment A	2.74	0.00321	0.960
Segment B	3.07	0.00327	0.993
Segment C	1.91	0.00245	0.965
Segment D	1.86	0.00233	0.904

Table 5. Linear fit parameters for VSD vs load cycles on outer wheel path.

	Intercept – Compaction (mm)	Slope – Wear rate (mm/1000 load cycles)	Goodness of fit – r^2
Segment A	5.37	0.00586	0.998
Segment B	4.68	0.00480	0.993
Segment C	2.24	0.00299	0.934
Segment D	2.30	0.00332	0.986

Table 6. Exponent values relating compaction and wear between the inner and outer wheel paths.

	Intercept - Compaction	Slope - Wear rate
Segment A	3.40	3.04
Segment B	2.13	1.94
Segment C	0.79	0.99
Segment D	1.06	1.77

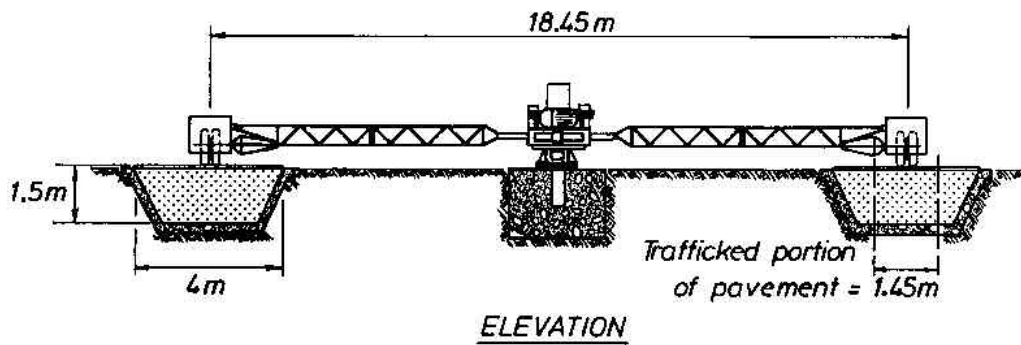

Figure 1 - Elevation view of CAPTIF.

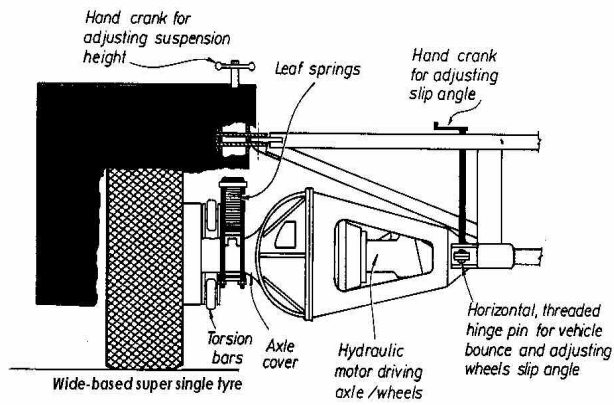

Figure 2 - The CAPTIF SLAVE unit.

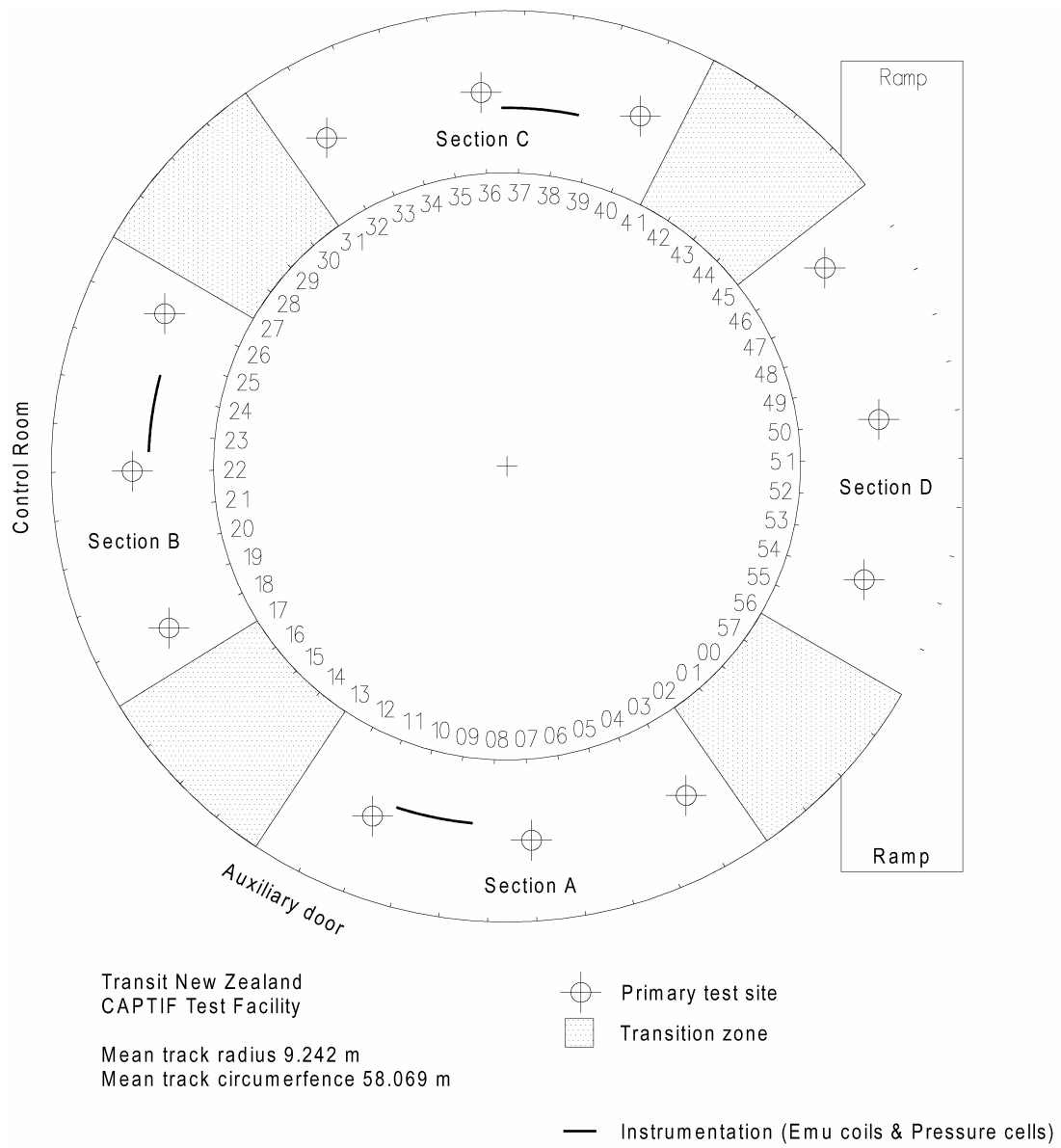

Figure 3. Plan showing the layout of the test sections.

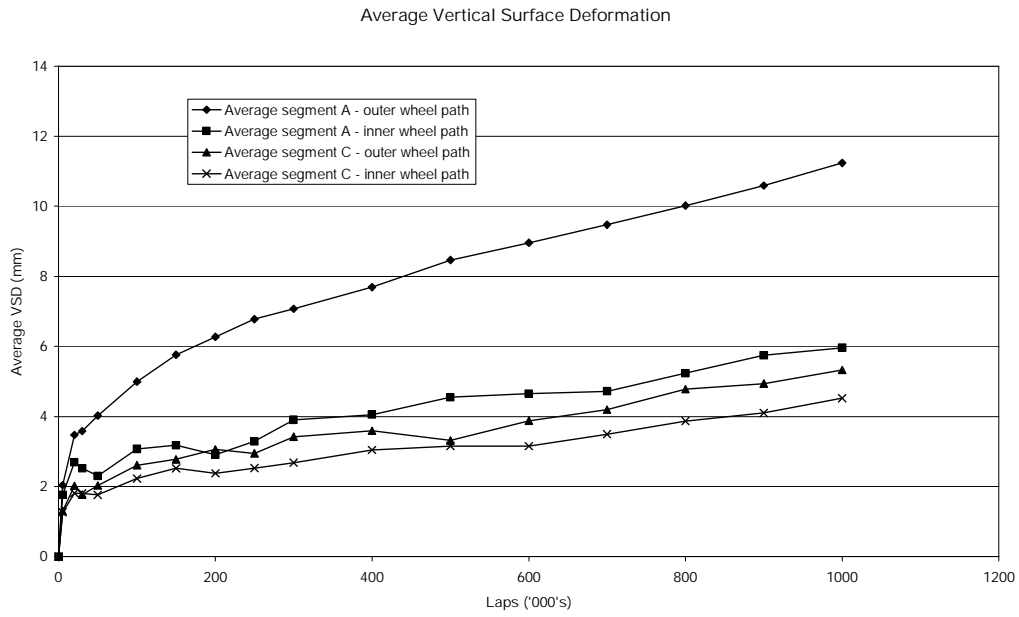

Figure 4. VSD for pavement segments A and C.

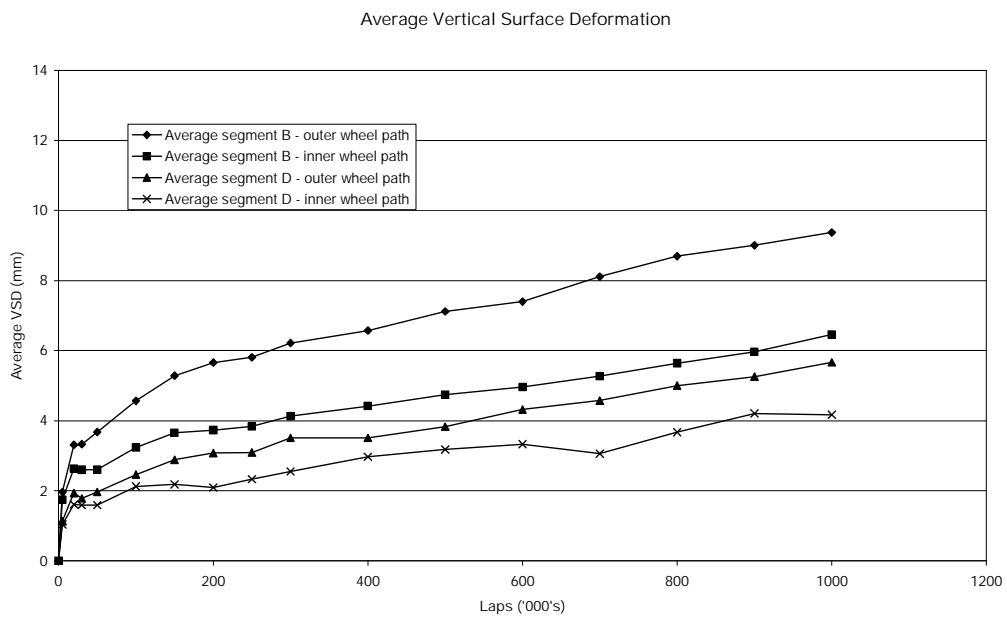

Figure 5. VSD for pavement segments B and D.

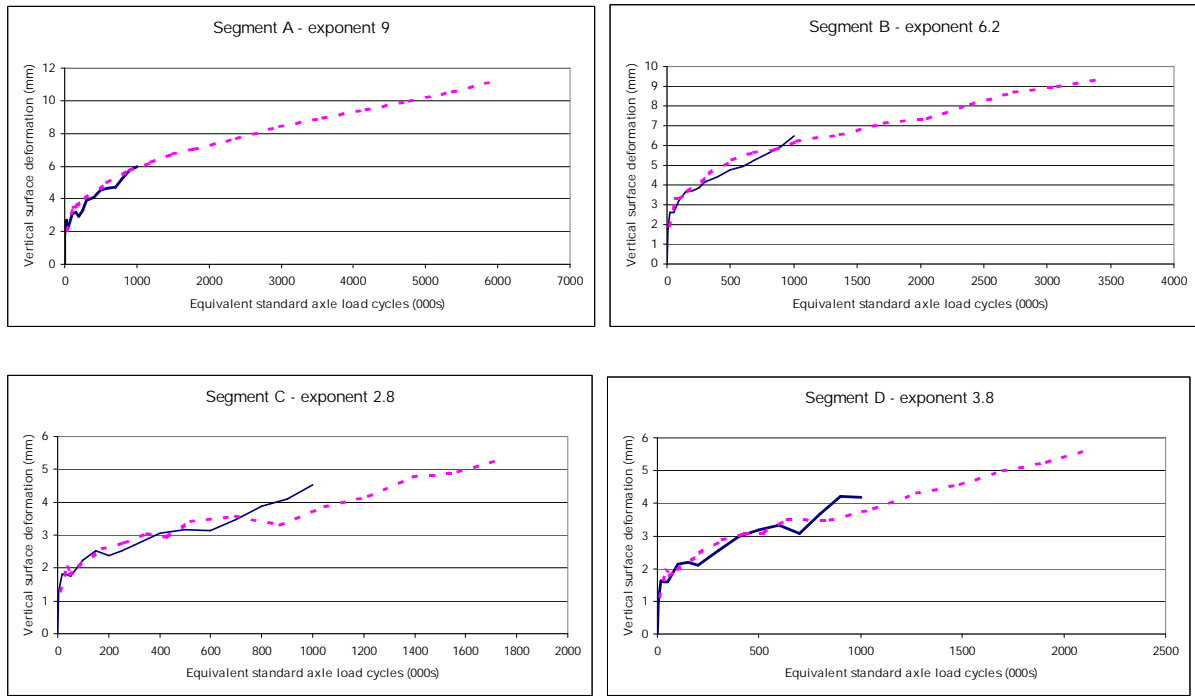

Figure 6. Power law fits to VSD for all four segments.

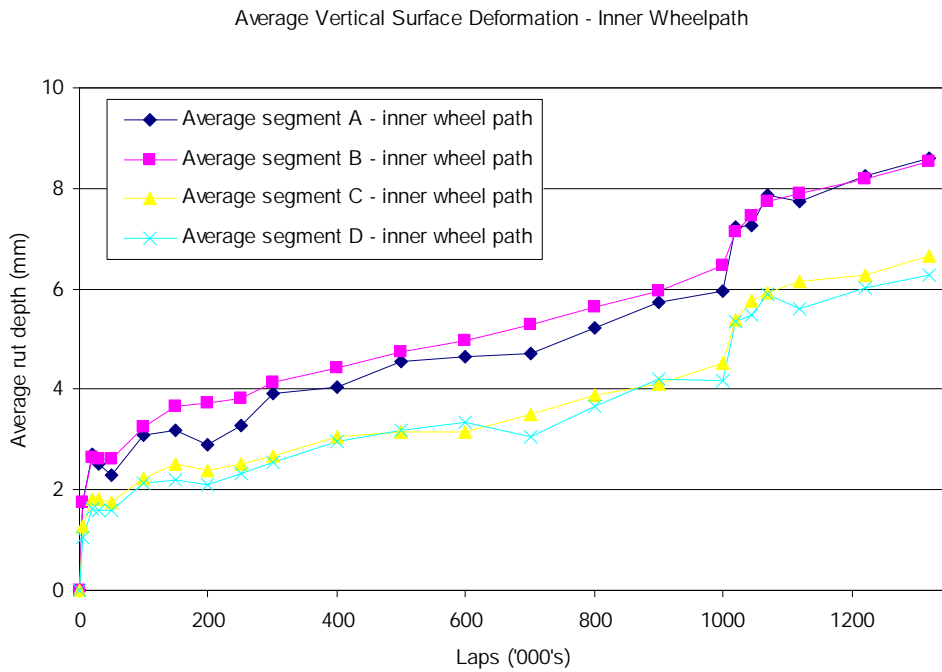

Figure 7. VSD vs load cycles for inner wheel path.